

Milling Chucks

MMC Hitachi Tool

No. 709

NIK Chuck High Balanced Collet Chuck
SUPER LOCK Milling Power Chuck
APC Advanced Precision Chuck
AMC Arbor Milling Chuck

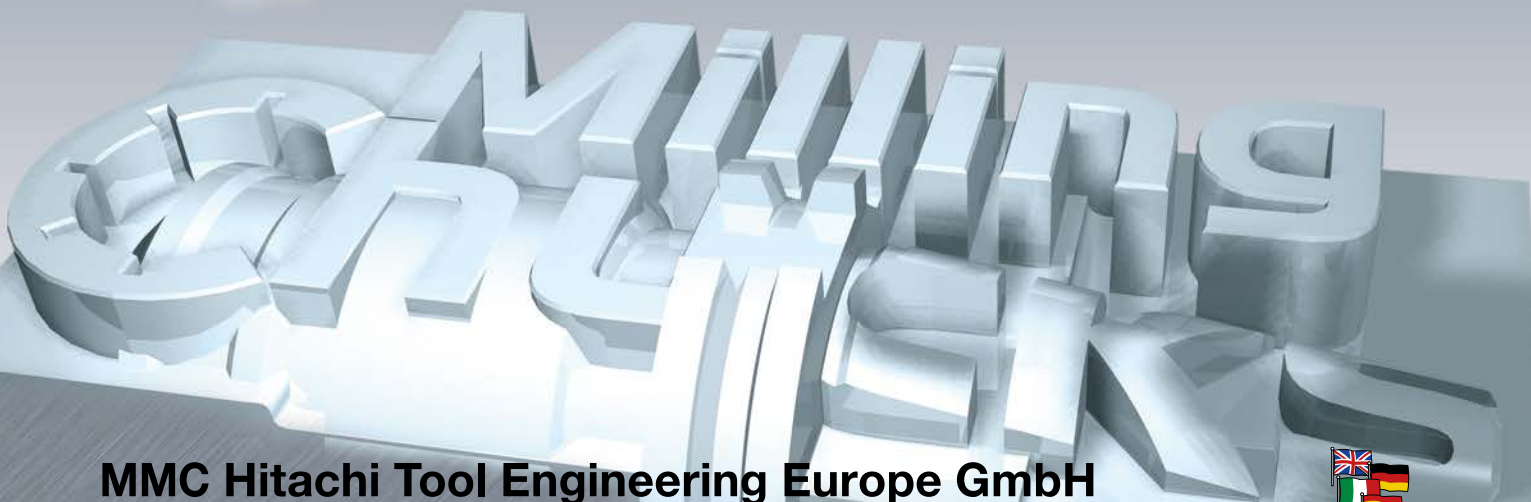
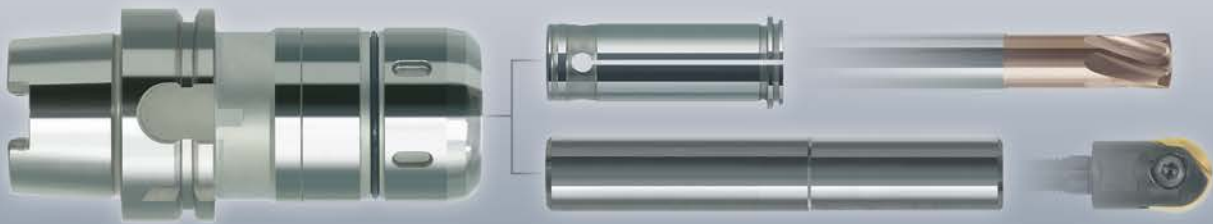

Milling Chucks

APC | Advanced Precision Chucks | HSK-E

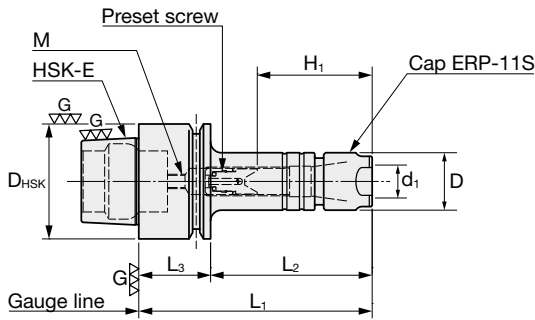

HSK25E = 10 mm
 HSK32E = 20 mm
 HSK40E = 20 mm
 HSK50E = 26 mm

ID Code	Item Code	Description	D	d ₁	H ₁	L ₁	L ₂	L ₃	M	D _{HSK}
NT059	HSK25E-APC11S-40	Micro Collet Chuck	16	11	29	40	30	10	3	25
NT060	HSK25E-APC11S-55				22-25	55	45			
NT061	HSK32E-APC11S-50				36	50	30			
NT062	HSK32E-APC11S-65				22-32	65	45	20	4	32
NT063	HSK40E-APC11S-50				36	50	30			
NT064	HSK40E-APC11S-65				22-29	65	45	26	6	50
NT065	HSK50E-APC11S-55				22-23	55	29			
NT066	HSK50E-APC11S-70				22-34	70	44			

APC | Advanced Precision Chucks | HSK-A

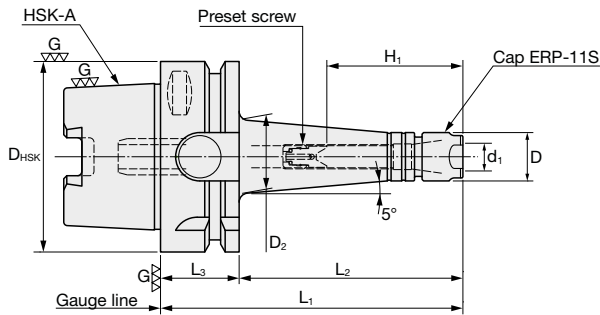

HSK63A = 26 mm

ID Code	Item Code	Description	D	d ₁	H ₁	L ₁	L ₂	L ₃	M	D _{HSK}
NT067	HSK63A-APC11S-70T	Micro Collet Chuck	16	11	22-29	70	44	26	-	63
NT068	HSK63A-APC11S-100T				100	74				
NT069	HSK63A-APC11S-130T				130	104				

APC | Collets for HSK APC

ID Code	Item Code	Description	Shank d
NT070	ER11-3,0	High Precision Collet	3
NT071	ER11-4,0		4
NT072	ER11-6,0		6



Spare Parts for HSK APC

ID Code	Item Code	Description
NT073	ERP-11S	Cap nut HSK APC
NT074	ES-11	Preset screw HSK APC
NT075	S-11E	Wrench for HSK APC



Milling Chucks

HSK 63 MD | DIN 69893 HSK

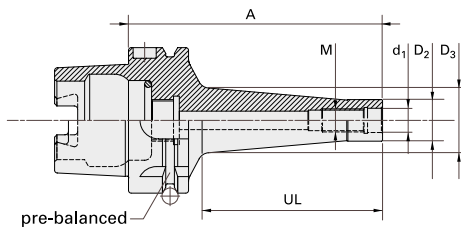

d ₁	+0
	+0.005

ID Code	Item Code	M	A	UL	d ₁	D ₂	D ₃
NT168	HKA063MD008025	8	60	25	8.5	13	15
NT184	HKA063MD008050		85	50			19
NT169	HKA063MD008075		110	75			22
NT185	HKA063MD008100		135	100			24
NT170	HKA063MD010025	10	60	25	10.5	18	23
NT186	HKA063MD010050		85	50			25
NT171	HKA063MD010075		110	75			28
NT187	HKA063MD010100		135	100			30
NT188	HKA063MD012025	12	60	25	12.5	21	24
NT172	HKA063MD012050		85	50			30
NT189	HKA063MD012075		110	75			32
NT173	HKA063MD012100		135	100			35
NT190	HKA063MD016025	16	60	25	17	29	29
NT174	HKA063MD016050		85	50			34
NT191	HKA063MD016075		110	75			37
NT175	HKA063MD016100		135	100			41

SK 40 MD | DIN 69871

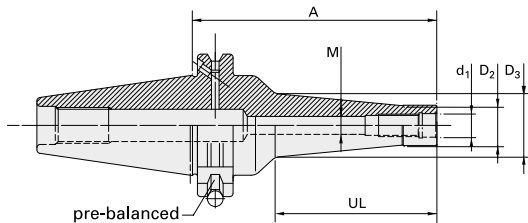

d ₁	+0
	+0.005

ID Code	Item Code	M	A	UL	d ₁	D ₂	D ₃
NT192	SKB040MD008010	8	50	10	8.5	13	13
NT176	SKB040MD008030		70	30			15
NT193	SKB040MD008050		90	50			20
NT177	SKB040MD008070		110	70			22
NT194	SKB040MD010010	10	50	10	10.5	18	18
NT178	SKB040MD010030		70	30			20
NT195	SKB040MD010050		90	50			25
NT179	SKB040MD010070		110	70			28
NT196	SKB040MD012010	12	50	10	12.5	21	21
NT197	SKB040MD012030		70	30			24
NT180	SKB040MD012050		90	50			28
NT198	SKB040MD012070		110	70			31
NT181	SKB040MD012090	130	90	33			
NT199	SKB040MD016010	16	50	10	17	29	29
NT200	SKB040MD016030		70	30			34
NT182	SKB040MD016050		90	50			37
NT201	SKB040MD016070		110	70			40
NT183	SKB040MD016090	130	90				

Milling Chucks

NIK12 | Nik Chuck - HSK DIN 69893 A+E - High Balanced

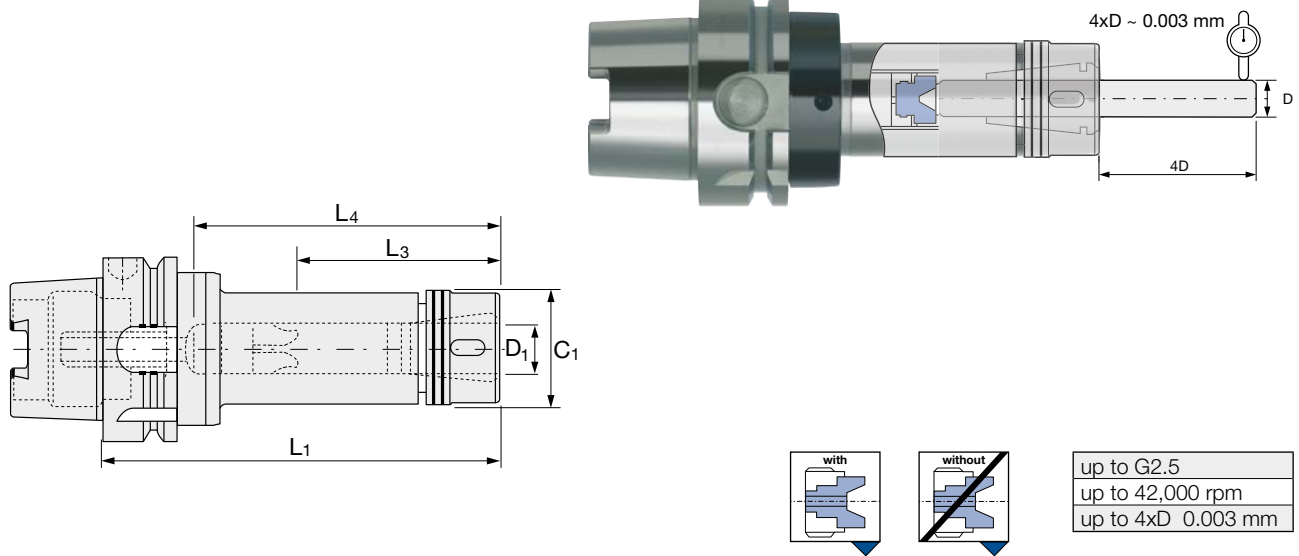

HSK-E							
ID Code	Item Code	D ₁ *	C ₁	L ₁	L ₃	L ₄	Weight/kg
NT121	HSK40E-NIK12-90G	3-12	34	90	-	*	0.8
NT116	HSK50E-NIK12-120G			120	33-70	- 80	0.9
HSK-A							
NT117	HSK63A-NIK12-120G	3-12	34	120	33-70	- 80	1.3
NT118	HSK100A-NIK12-150G			150		-100	3.3

* Collets on p. 3

NIK12 | Nik Chuck - SK DIN 69871 / MAS-BT40 – High Balanced

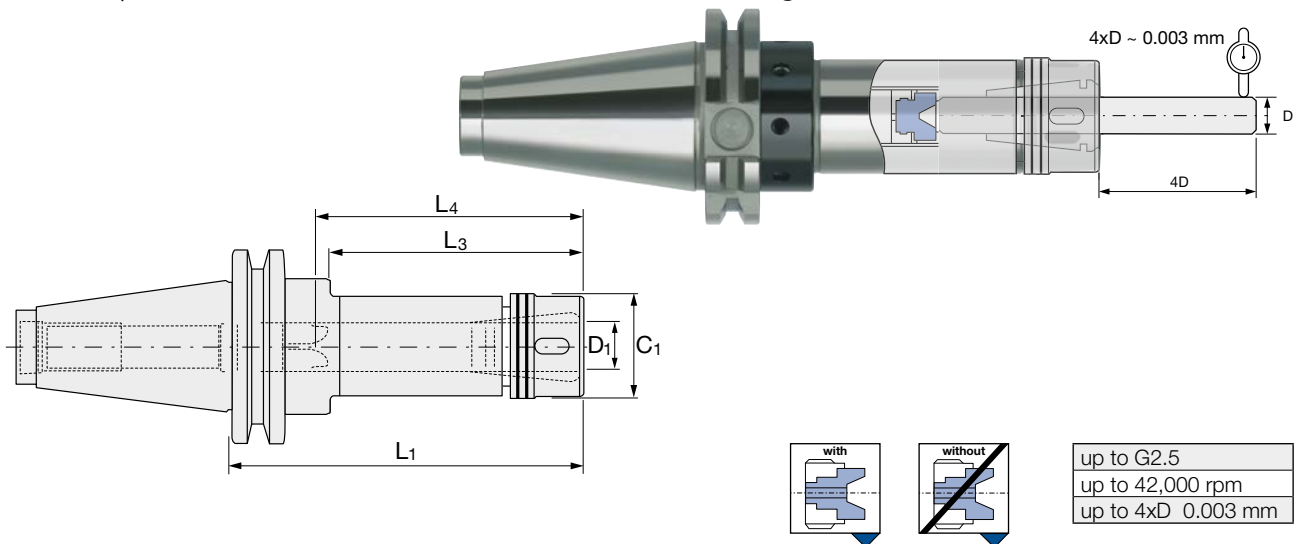

ID Code	Item Code	D ₁ *	C ₁	L ₁	L ₃	L ₄	Weight/kg
NT115	SK40-NIK12-120G	3-12	34	120	33-70	- 85	1.4
NT114	BT40-NIK12-120G	3-12	34	120	33-70	- 85	1.6

* Collets on p. 3

SPECIAL FEATURES

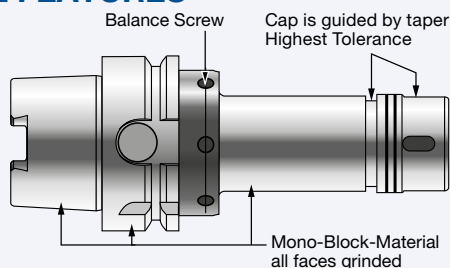

- 1. Balance Screw 2. Cap is guided by taper – Highest Tolerance 3. Mono-Block-Material – all faces grinded
- 1. Wuchtschraube 2. Kappe mit Konusführung – höchste Präzision 3. Monoblock-Material – alle Oberflächen geschliffen
- 1. Vite di bilanciamento 2. La ghiera è guidata dal filetto – massima tolleranza 3. Realizzato da un singolo blocco – superfici rettificata
- 1. Tornillo de equilibrado 2. Tuerca de apriete de guiado cónico para una alta precisión 3. Cuerpo de una sola pieza con todas las caras rectificadas
- 1. Vis d'équilibrage 2. Embout guidé par la partie cylindrique rectifiée – tolérance élevée 3. Matériau monobloc – surfaces intégralement rectifiées
- 1. Parafuso calibrado 2. Guia orientada pelo cone – maior tolerância 3. Material mono-bloco – todas as faces retificadas

Milling Chucks

FDC-OHAA | Nik Chuck – Collets for NIK12

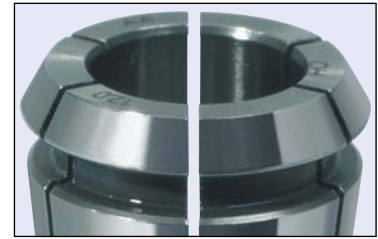
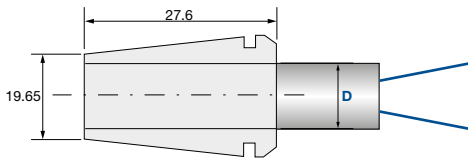

ID Code	Item Code	D
NT102	FDC-03012OHAA	3
NT103	FDC-04012OHAA	4
NT033	FDC-05012OHAA	5
NT104	FDC-06012OHAA	6
NT034	FDC-07012OHAA	7
NT105	FDC-08012OHAA	8
NT035	FDC-09012OHAA	9
NT106	FDC-10012OHAA	10
NT036	FDC-11012OHAA	11
NT107	FDC-12012OHAA	12
NT119	SET-FDCOHAA	3, 4, 6, 8, 10, 12

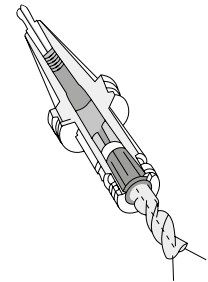

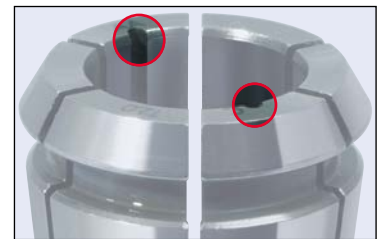
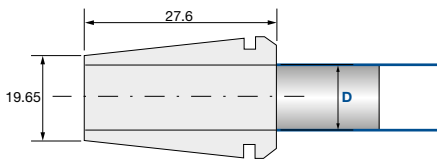

FDC-CAA | Nik Chuck – Collets for NIK12

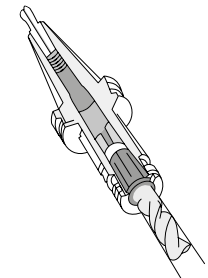

ID Code	Item Code	D
NT108	FDC-03012CAA	3
NT109	FDC-04012CAA	4
NT110	FDC-06012CAA	6
NT111	FDC-08012CAA	8
NT112	FDC-10012CAA	10
NT113	FDC-12012CAA	12
NT120	SET-FDCCAA	3, 4, 6, 8, 10, 12

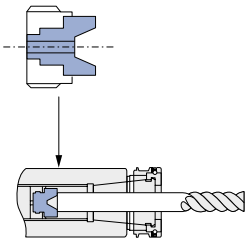

Spare Parts for NIK12

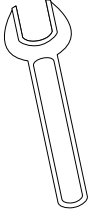
Parts	Pre-set screw	Cap	Wrench	Wrench
				
Item Code	ID Code	ID Code	ID Code	
HDS-12	NT123			
GDP-12		NT122		
FK-0030			NT127	
S-3L			NT124	
HDP-12		NT233		
S-1			NT024	

Milling Chucks

SUPER LOCK | Milling Power Chuck - HSK DIN 69893 A



HSK 63 A M18 x 1.0
HSK 100 A M24 x 1.5

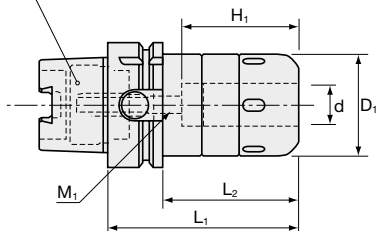

Type 1) CT20S max. 20,000 rpm
1,500 N/m Power

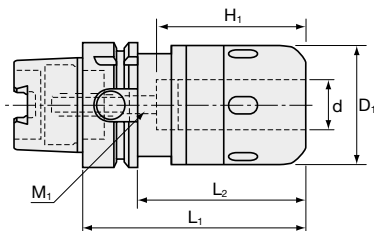

Type 2) CT32S max. 15,000 rpm
4,000 N/m Power

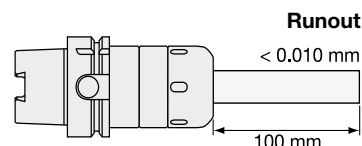

HSK63A									
ID Code	Item Code	Type	d	D ₁	L ₁	L ₂	M ₁	H ₁	
NT098	HSK63A-CT20S-105	1	20	52	105	79	M8	75	
NT126	HSK63A-CT32S-120G	2	32	73	120	94	M8	90	

HSK100A									
ID Code	Item Code	Type	d	D ₁	L ₁	L ₂	M ₁	H ₁	
NT231	HSK100A-CT20S-105	1	20	52	105	76	M10	70	
NT099	HSK100A-CT32S-135	2	32	73	135	106	M10	100	

Content of Sets:				
ID Code	Item Code	Content *		
NT101	SET-HSK63-CT20	1x HSK63A-CT20S-105	(Chuck)	* Info: see p.5 below * Info: siehe S. 5 unten * Per maggiori informazioni consultare pagina 5 seguente * Info: ver pág. 5 abajo * Info: voir ci-après p. 5 * Para mais informação, ver final de pág. 5.
		incl. 5 MC20 Collets	(Collets)	
NT079	SET-HSK63-CT32	1x HSK63A-CT32S-120G	(Chuck)	
		incl. 7 MC32 Collets	(Collets)	
NT076	SET-HSK100-CT20	1x HSK100A-CT20S-105	(Chuck)	
		incl. 5 MC20 Collets	(Collets)	
NT100	SET-HSK100-CT32	1x HSK100A-CT32S-135	(Chuck)	
		incl. 7 MC32 Collets	(Collets)	

HKA063xxx:

Attention!

Please check your spindle system on the machine if there is an inner coolant pipe needed.
Please ask your machine manufacturer if you are not sure. For a following damage/ mistake we will not guarantee!

Achtung!

Bitte prüfen Sie Ihr Spindel-System, ob Sie für die innere Kühlmittel-zufuhr eine Hülse in der Aufnahme benötigen.
Sollten Sie nicht sicher sein, ziehen Sie bitte Ihren Maschinenhersteller zu Rate. Für eventuell auftretende Beschädigungen können wir keine Garantie übernehmen!

Attenzione!

Si prega di controllare se nel mandrino della vostra macchina utensile è necessario avere il tubo per il refrigerante interno.
Si prega di contattare il costruttore della macchina se non si è sicuri. Per eventuali danni/errori dovuti all'omesso controllo non garantiremo

¡Importante!

Por favor compruebe si el cabezal de su máquina requiere un manguito para la refrigeración interna. Pregunte al fabricante de la máquina si Ud. no está seguro.

¡En caso de avería no nos haremos responsables de la misma!

Attention !

Veillez, SVP, vérifier si votre système de broche nécessite l'utilisation d'un tube d'arrosage par le centre. Si vous n'êtes pas certain, veuillez, SVP, demander au fabricant de la machine.

Nous déclinons toute responsabilité en cas de dommage et ou d'erreur, liés à l'utilisation ou non du tube d'arrosage !

Atenção:

Por favor, verifique se a sua cabeça da máquina requer dispositivo para arrefecimento interno. Pergunte ao fabricante da máquina se não tiver certeza. Em caso de falha não se responsabilizamos pela sua falta!

Parts	Wrench	
Item Code	ID Code	Item Code
for CT20S	NT009	HS-2
for CT32S	NT010	HS-3

Milling Chucks

SUPER LOCK | Milling Power Chuck - SK DIN 69871

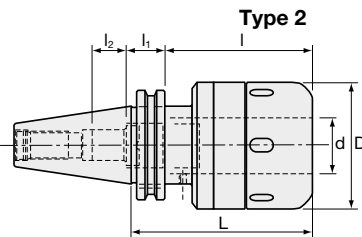
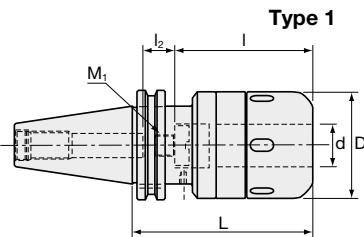

Type 1) CT20S max. 20,000 rpm
1,500 N/m Power

Type 2) CT32S max. 15,000 rpm
4,000 N/m Power

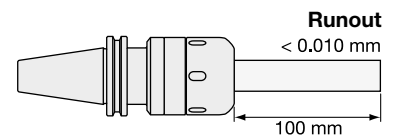

ID Code	Item Code	Type	d	D	L	l	l ₁	M ₁	l ₂
NT029	SK40-CT20S90	1	20	52	90	80	-	12	15
NT129	SK40-CT32S-105	2	32	73	105	85	23	18	20
NT232	SK50-CT20S105	1	20	52	105	80	-	12	15
NT030	SK50-CT32S105	2	32	73	105	120	-	18	20
NT001	BT40-CT20S90	1	20	52	90	80	-	12	15
NT002	BT50-CT32S105	2	32	73	105	120	-	18	20
NT235	BT40-CT32S105	2	32	73	105	120	23	18	20

Content of Sets:

ID Code	Item Code	Content *
NT027	SET-SK40-CT20	1x SK40-CT20S90 (Chuck)
		incl. 5 MC20 Collets (Collets)
NT077	SET-SK50-CT20	1x SK50-CT20S105 (Chuck)
		incl. 5 MC20 Collets (Collets)
NT028	SET-SK50-CT32	1x SK50-CT32S105 (Chuck)
		incl. 7 MC32 Collets (Collets)
NT078	SET-SK40-CT32	1x SK40-CT32S-105 (Chuck)
		incl. 7 MC32 Collets (Collets)
NT025	SET-BT40-CT20	1x BT40-CT20S90 (Chuck)
		incl. 5 MC20 Collets (Collets)
NT236	SET-BT40-CT32	1x BT40-CT32S105 (Chuck)
		incl. 7 MC32 Collets (Collets)
NT026	SET-BT50-CT32	1x BT50-CT32S105 (Chuck)
		incl. 7 MC32 Collets (Collets)

* Info: see below

* Info: siehe unten

* Per maggiori informazioni: vedi sotto

* Info: ver más abajo

* Info: voir ci-dessous

* Para mais informação: ver abaixo

* The diameters and milling chucks (type 1 or type 2) can be freely combined as set with the collets.

* Die Durchmesser und die Spannzange (Typ 1 oder Typ 2) sind als Set mit den Hülsen frei kombinierbar.

* I mandrini (Tipo 1 o Tipo 2), nei vari diametri, possono essere abbinati a pinze a scelta creando un SET

* Los diferentes tamaños de conos (tipo 1 o tipo 2) se pueden combinar libremente como Set con las pinzas

* Les attachements permettent de combiner des mandrins et des pinces de diamètres différents (type 1 ou type 2).

* Os cones e respectivos diâmetros (tipo 1 ou tipo 2) podem ser livremente combinados em SETs com as pinças.

Parts		Wrench		
Item Code	ID Code	Item Code	ID Code	Item Code
for CT20S	NT009	HS-2		
for CT32S	NT010	HS-3		
for EM2019A			NT024	S-1

Milling Chucks

MC20 | Collets for CT20S

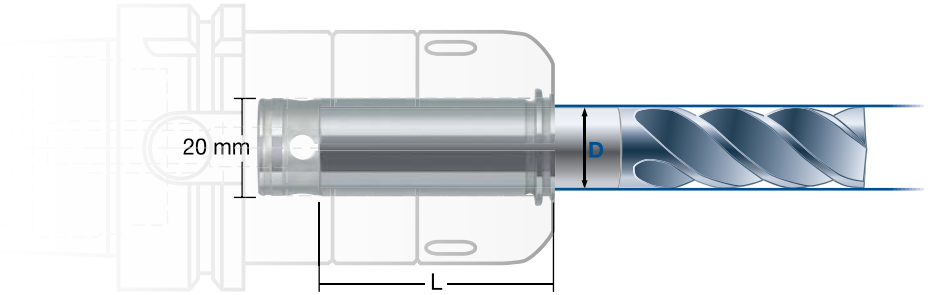

ID Code	Item Code	Shank D	Chucking Length L*
NT085	MC20-3	3	30 mm
NT014	MC20-4	4	
NT015	MC20-6	6	
NT016	MC20-8	8	
NT011	MC20-10	10	40 mm
NT012	MC20-12	12	
NT081	MC20-14	14	
NT013	MC20-16	16	
NT083	MC20-18	18	
-	-	20	

* Recommended Chucking Length of Cutting Tool

UK Note: The closed version (OH) is also available with unequal diameters (please see below).

DE Hinweis: Die geschlossene Version (OH) ist auch mit ungeraden Durchmessern verfügbar (siehe unten).

IT Nota: La versione a tenuta (OH) è disponibile anche con diametri dispari (vedi sotto).

ES Nota: La versión cerrada (OH) también está disponible con diámetros impares (ver más abajo)

FR Note : Différents diamètres (voir ci-dessous) sont également disponibles pour cette référence (OH).

PT Nota: A versão fechada (OH) está também disponível para diâmetros ímpares (ver abaixo).

MC20-OH | Collets for CT20S

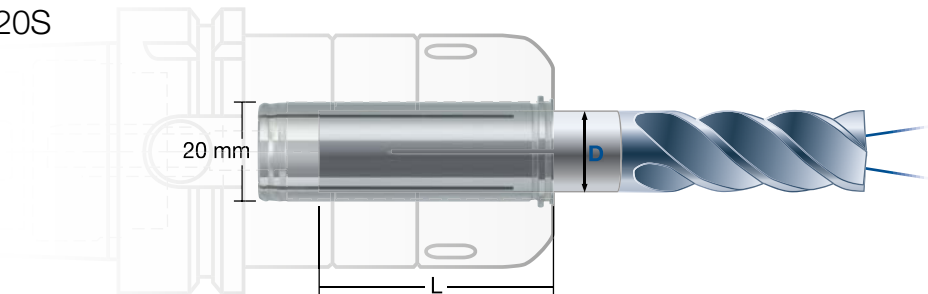

ID Code	Item Code	Shank D	Chucking Length L*
NT086	MC20-3OH	3	30 mm
NT042	MC20-4OH	4	
NT043	MC20-5OH	5	
NT044	MC20-6OH	6	
NT045	MC20-7OH	7	
NT046	MC20-8OH	8	
NT047	MC20-9OH	9	40 mm
NT037	MC20-10OH	10	
NT038	MC20-11OH	11	
NT039	MC20-12OH	12	
NT040	MC20-13OH	13	
NT082	MC20-14OH	14	
NT080	MC20-16OH	16	
NT084	MC20-18OH	18	
-	-	20	

* Recommended Chucking Length of Cutting Tool

Milling Chucks

MC32 | Collets for CT32S

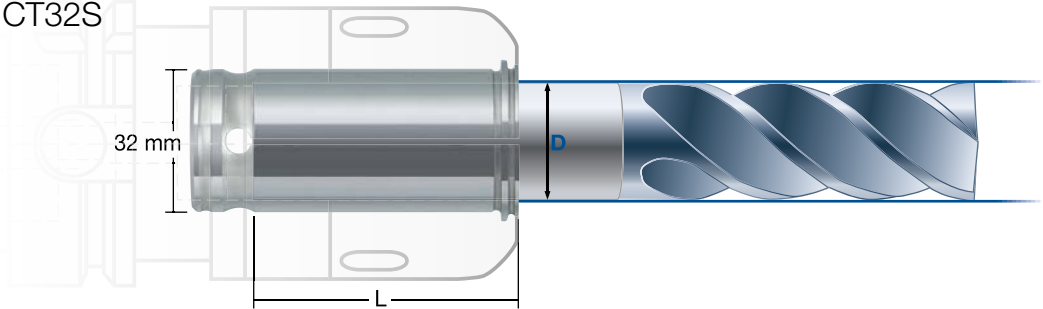

ID Code	Item Code	Shank D	Chucking Length L*
NT091	MC32-3	3	30 mm
NT093	MC32-4	4	
NT022	MC32-6	6	
NT023	MC32-8	8	40 mm
NT017	MC32-10	10	
NT018	MC32-12	12	
NT087	MC32-14	14	
NT019	MC32-16	16	
NT089	MC32-18	18	50 mm
NT020	MC32-20	20	
NT021	MC32-25	25	
-	-	32	

* Recommended Chucking Length of Cutting Tool

UK Note: The closed version (OH) is also available with unequal diameters (please see below).

DE Hinweis: Die geschlossene Version (OH) ist auch mit ungeraden Durchmessern verfügbar (siehe unten).

IT Nota: La versione a tenuta (OH) è disponibile anche con diametri dispari (vedi sotto).

ES Nota: La versión cerrada (OH) también está disponible con diámetros impares (ver más abajo)

FR Note : Différents diamètres (voir ci-dessous) sont également disponibles pour cette référence (OH).

PT Nota: A versão fechada (OH) está também disponível para diâmetros ímpares (ver abaixo).

MC32-OH | Collets for CT32S

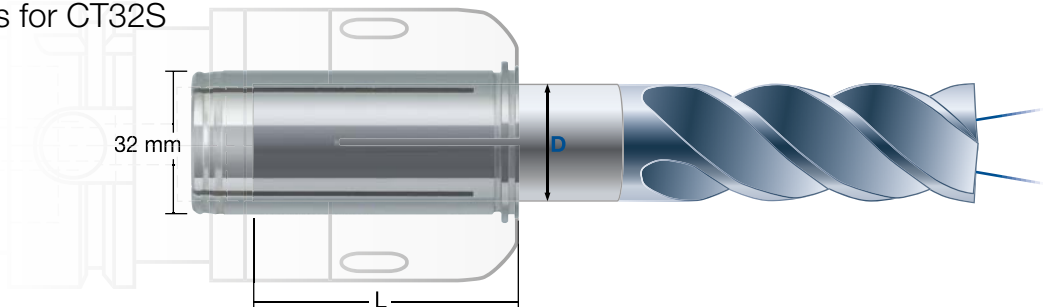

ID Code	Item Code	Shank D	Chucking Length L*
NT092	MC32-3OH	3	30 mm
NT052	MC32-4OH	4	
NT053	MC32-5OH	5	
NT054	MC32-6OH	6	40 mm
NT055	MC32-7OH	7	
NT056	MC32-8OH	8	
NT057	MC32-9OH	9	
NT048	MC32-10OH	10	
NT049	MC32-11OH	11	50 mm
NT151	MC32-12OH	12	
NT050	MC32-13OH	13	
NT088	MC32-14OH	14	50 mm
NT152	MC32-16OH	16	
NT090	MC32-18OH	18	
NT153	MC32-20OH	20	50 mm
NT154	MC32-25OH	25	
-	-	32	

* Recommended Chucking Length of Cutting Tool

Indexable Milling Tools

ASC | Carbide Shanks for Modular Mills

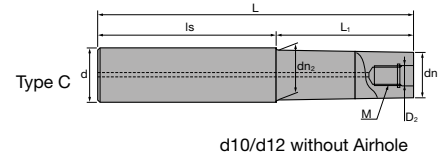
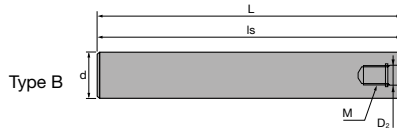
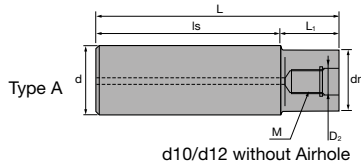

Carbide Shank																
	ID Code	Item Code	D ₂	M	L	L ₁	Is	dn	dn ₂	d	Type					
Without Airhole	FH137	ASC10-6.5-74-24	6.5	M6	74	24	50	9.3	-	10	A					
	FH254	ASC10-6.5-84-34			84	34										
	FH255	ASC10-6.5-114-24			114	24						90				
	FH138	ASC10-6.5-114-49			114	49	65									
	FH139	ASC12-6.5-74-24			74	24	50					11	11.5	12	C	
	FH256	ASC12-6.5-94-44			94	44										
	FH257	ASC12-6.5-129-24			129	24										105
	FH140	ASC12-6.5-129-64			129	64										65
With Airhole	FH141	ASC16-8.5-95-30	8.5	M8	95	30	65	14.5	15.5	16	C					
	FH258	ASC16-8.5-120-55			120	55										
	FH142	ASC16-8.5-140-75			140	75										
	FH260	ASC16-8.5-160-30			160	30						130				
	FH259	ASC16-8.5-160-95			160	95						65				
	FH143	ASC20-10.5-120-50	10.5	M10	120	50	70	18	-	20	A					
	FH261	ASC20-10.5-170-90Z			170	90	80	18.5	19.5		C					
	FH144	ASC20-10.5-220-50			220	50	170	18	-		A					
	FH262	ASC20-10.5-220-120Z			220	120	100	18.5	19.5		20	C				
	FH263	ASC20-10.5-270-150Z			270	150	120									
	FH264	ASC20-10.5-270-50Z			270	50	220									
	FH145	ASC25-12.5-145-65	12.5	M12	145	65	80	23	-	25	A					
	FH146	ASC25-12.5-265-65			265		200									
	FH265	ASC25-12.5-215-115			215	115	100									
	FH266	ASC25-12.5-265-145			265	145	120									
	FH268	ASC25-12.5-315-65			315	65	250									
	FH267	ASC25-12.5-315-195			315	195	120									
	FH147	ASC32-17-160-80	17	M16	160	80	80	28	-	32	A					
FH269	ASC32-17-260-140	260			140	120										
FH148	ASC32-17-310-80	310			80	230										
FH270	ASC32-17-360-240	360			240	120										

- SUPER Lock milling chucks or shrink-fit holders can be used.
- SUPER Lock Aufnahmen oder Schrumpffutter können verwendet werden.
- Possono essere utilizzati mandrini a forte serraggio SUPER Lock.

- Aptos para amarrar en portapinzas SUPER Lock.
- Les attachements SUPER Lock peuvent être utilisés.
- Cones hidráulicos de grande aperto e aperto térmico podem ser usados.

Indexable Milling Tools

AS | Steel Shanks for Modular Mills

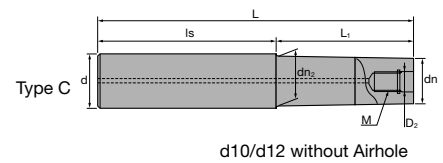
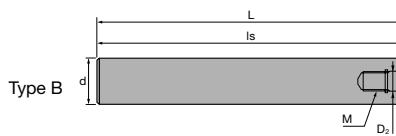
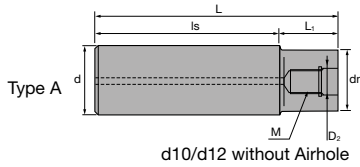

		Steel Shank										
		ID Code	Item Code	D ₂	M	L	L ₁	Is	dn	dn ₂	d	Type
Without Airhole	FH131	AS10-6.5-74-0	6.5	M6	74	–	74	–	–	–	10	B
	FH132	AS12-6.5-84-4			84	4	80	11	–	12	A	
With Airhole	FH133	AS16-8.5-95-15	8.5	M8	95	15	80	14.5	15.5	16	A	
	FH134	AS20-10.5-100-20	10.5	M10	100	20		18	–	20		
	FH271	AS25-12.5-115-35	12.5	M12	115	35		23	23	25		
	FH272	AS32-17-110-30	17	M16	110	30		28	28	32		

🇬🇧 SUPER Lock milling chucks can be used.

🇩🇪 SUPER Lock Aufnahmen können verwendet werden.

🇮🇹 Possono essere utilizzati mandrini a forte serraggio SUPER Lock.

🇪🇸 Aptos para amarrar en portapinzas SUPER Lock.

🇫🇷 Les attachements SUPER Lock peuvent être utilisés.

🇵🇹 Cones hidráulicos de grande aperto e aperto térmico podem ser usados.

🇬🇧 For further information about modular chucks please see our brochure *Indexable Modular Series No. 328.2*

🇩🇪 Weitere Informationen über modulare Werkzeugaufnahmen finden Sie in unserem Prospekt: *Indexable Modular Series No. 328.2*

🇪🇸 Para obtener más información sobre conos modulares consulte nuestro folleto *Indexable Modular Series No. 328.2*

🇮🇹 Per maggiori informazioni riguardanti la gamma dei mandrini avvitabili consultate il catalogo *Indexable Modular Series No. 328.2*

🇫🇷 Pour de plus amples informations concernant les attachements modulaires, consultez SVP notre brochure *Indexable Modular Series No. 328.2*

🇵🇹 Para mais informações sobre Cones Modulares consulte o nosso folheto *Indexable Modular Series No. 328.2*

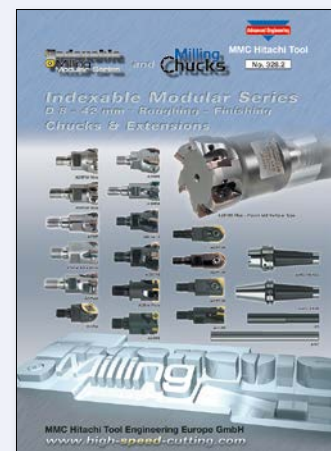

Always up to date: Please check our P50 QuickFinder



Product Range

Solid Carbide End Mills



Indexable Milling Tools



WHNSB Drills



Milling Chucks



Distributed by:

MMC Hitachi Tool Engineering Europe GmbH

Itterpark 12 · 40724 Hilden · Germany · Phone +49 (0) 21 03-24 82-0 · Fax +49 (0) 21 03-24 82-30
E-Mail info@mmc-hitachitool-eu.com · Internet www.mmc-hitachitool-eu.com
© 2016 by MMC Hitachi Tool Engineering Europe GmbH · Printed in Germany